

GOLDMAN LAND CRUISER

installation instruction



■ Read this instruction manual before starting installation. ■

- The vehicle must be stayed on a flat floor when doing installation work of this item. •Work this installation with more than 2 people.
- Be sure to stop the engine & apply the parking brake. •Before putting Both Side Adhesive Tapes and Moldings, Clean up the applying surface of the vehicle with White Gasoline or chemical can wipe off silicon, oil, dirt and so on. Do not wash the vehicle for 24hrs after applying Both Side Adhesive Tapes to avoid unstuck.
- If you fail an installation of Both Side Tapes or Moldings, do not use them again. Dry & warm up the surface of Both Side Adhesive Tapes & Moldings applying area with a hair dryer before the installation in a cold or high humidity day.
- Read the instruction notes before working with the Primer. •Before starting work if there is anything related to electric, take off the minus post from battery.

Primer (N200PAC) Adhesion Promoter
Care & Attention.

- Drying out for more than 10 minutes after coating.
- Careful not to come off the Primer (the adhesion promoter) from the applying area.
- If the adhesion promoter came off, wipe it off immediately with absorbent cotton or sootherwise the come off area will be yellowish.

Over Fender

■ Over fenders installation. ■ Be sure to install the Front Under Spoiler first when you install both the front under spoiler & over fenders.

1. Be sure to do trial fitting before painting the Over Fenders.
2. With white gasoline or chemical which can remove Silicon, Oil, Dirt and so on from the Over Fenders, the LAND CRUISER Stock Molding & the Double-stick tapes applying area on the vehicle, then coating PAC Primer [A].
3. Attach the Rubber Molding [B] & the Double-stick tapes [C] on the Over Fenders. (Ref.Fig. 1,2,3,4) Put the Speed Nuts [D] to the Over Fenders on the Rear Door. (Ref.Fig. 4)
4. Remove the LAND CRUISER Stock Bolts & Clips from the Over Fenders installation area. These will be reused later.
5. Cut off the 2 points (See Ref. Fig. 10) for 2mm on front fender with a disc grinder and put the Speed Nuts [E].
6. Peel off 2cm each ends of the release paper of Double-stick tapes [C] on the Front Over Fenders, then put them on the vehicle with the LAND CRUISER Genuine bolts & clips temporary. The Part of Fig. 10 use Truss Bolt [F]. Tighten up the Rear Over Fender's inner back side of bottom part with Truss Bolts [F] & Fringe Nuts [L]. (Ref.Fig. 6)
7. Take off all of the release paper of Double-stick tapes and press the Over Fenders against the vehicle.
8. Do Final Tightening work of LAND CRUISER Genuine Bolts, Clips & Truss Bolts [F].
9. Tighten up Tapping Screw [G], [H] & [M]. (Tuck in Rubber Washer [I] for any clearance Gaps.)
10. Make 6mm dia. Holes on the Rear Door with a Drill. Template Gauge [J] shows the drilling positions. (Ref.bottom of Fig. 5)
11. First align the each Rear Over Fender (Door side and Fender Side), then press the Door Side of Over Fenders against the door.
12. Tighten up Truss Bolt [K] from inside of the door. (Ref.Fig. 5)

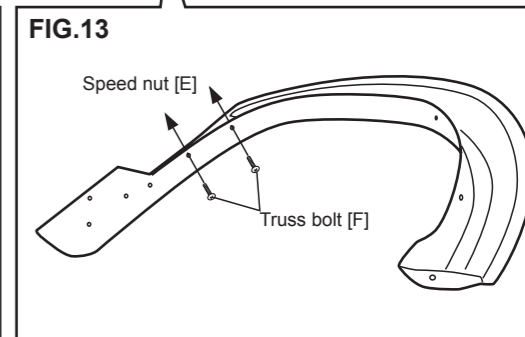
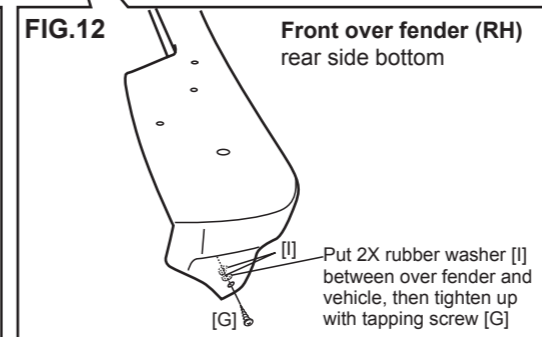
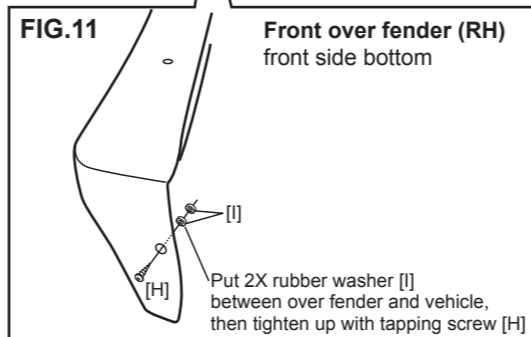
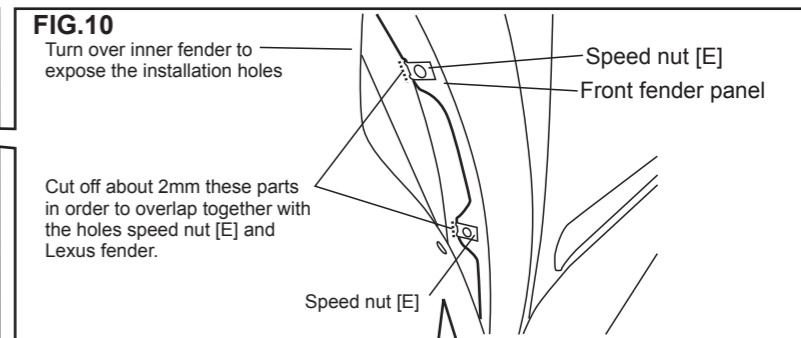
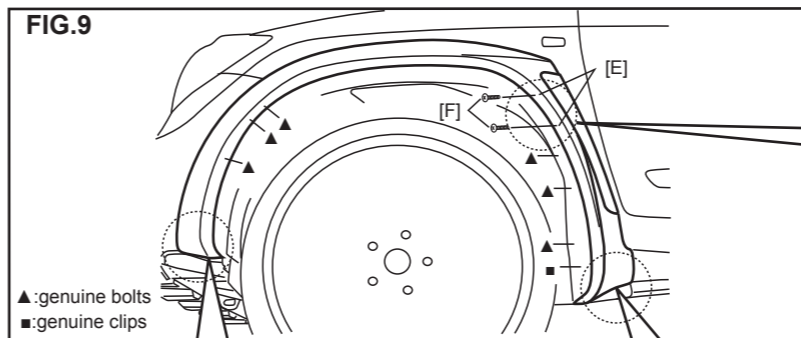
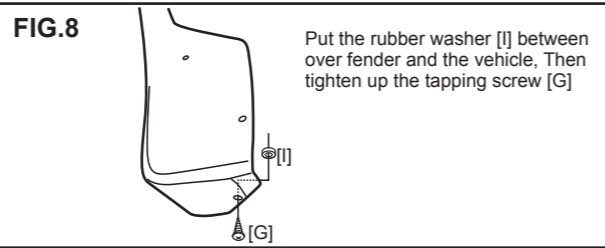
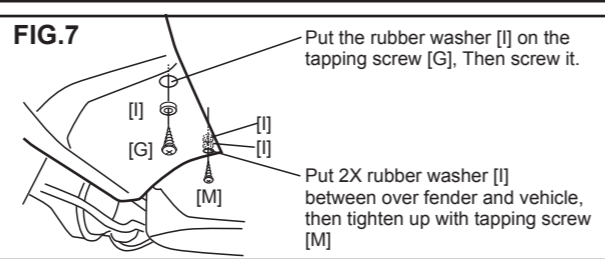
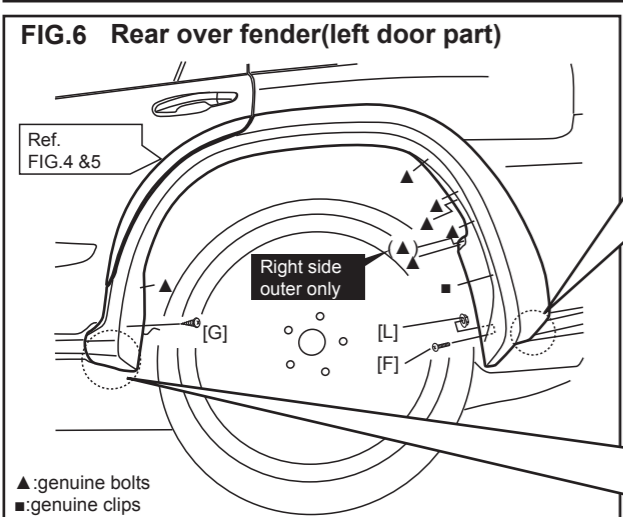
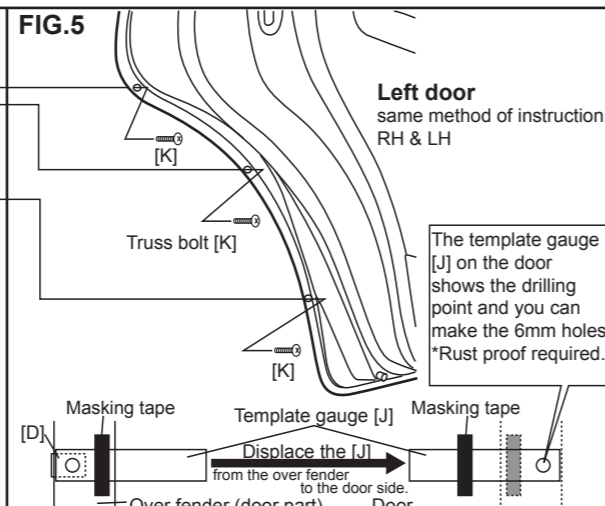
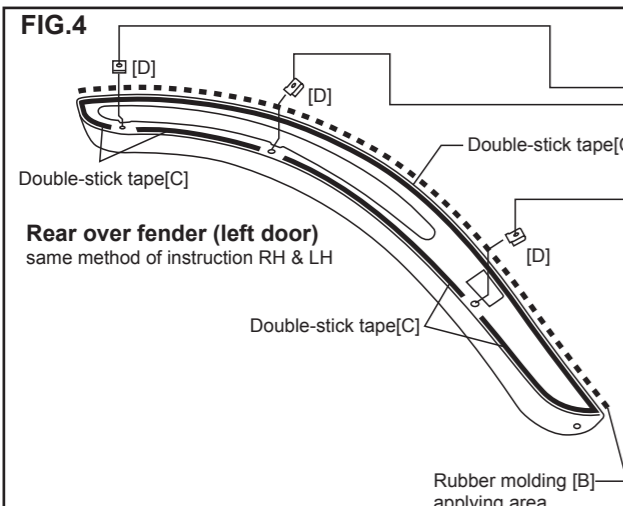
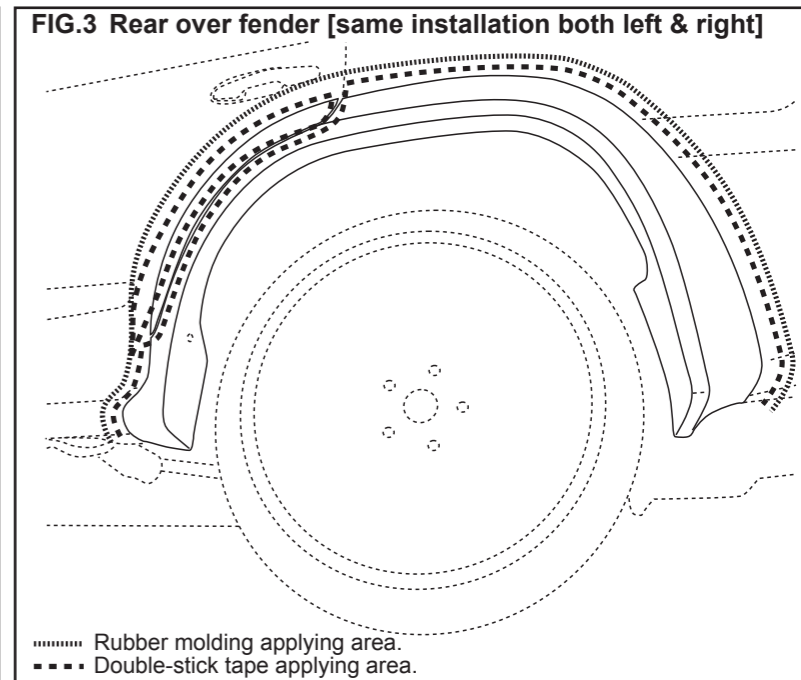
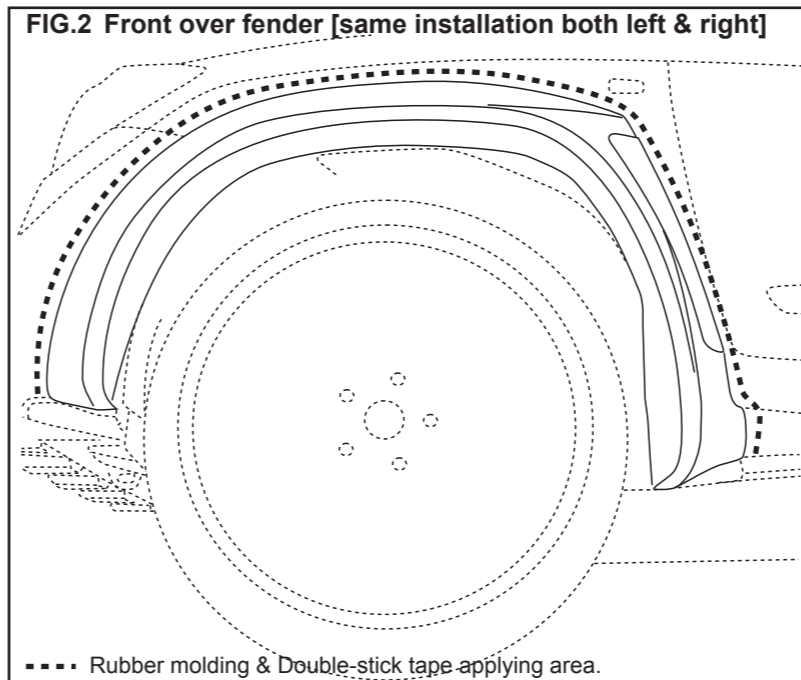
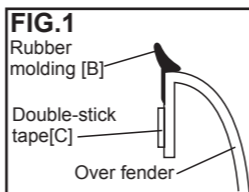

List of Parts	A	PAC Primer N200 adhesion promoter	2	D	Speed nut M5	6	H	Tapping screw 6x25mm	2	L	Fringe nut M6	2
	B	Rubber molding (opt black or gray molding to match up the body color.)	4	E	Speed nut M6	4	I	Rubber washer	20	M	Tapping screw 5x25mm	2
	C	Double-stick tape	2	F	Truss bolt M6	6	J	Template gauge	1			
				G	Tapping screw 5x20mm	8	K	Truss bolt M5	6			

DAMD Inc.

45-1 Shimotsuruma Yamato Kanagawa Japan
 TEL.81-46-271-5599 FAX.81-46-272-2266
<http://www.damd.co.jp>